

SURGE VOLTAGE PROTECTION

TOP-TECHNIC



SURGE ARRESTER

TOP-TECHNIC



SURGE ARRESTERS, CLASS I + II (B/C) – 25 kA (10/350) / 12,5 kA (10/350)

TOP-TECHNIC



SURGE ARRESTERS, CLASS I + II (B/C)

TOP-TECHNIC



SURGE ARRESTERS, CLASS I (B)

TOP-TECHNIC



SURGE ARRESTERS, CLASS II (C)

TOP-TECHNIC



SURGE ARRESTERS, CLASS III (D)

SURGE VOLTAGE PROTECTION

CONTENTS

SURGE ARRESTER

SURGE ARRESTERS, CLASS I + II (B/C) – 25 kA (10/350)

SURGE ARRESTERS, CLASS I + II (B/C) – 12,5 kA (10/350)

SURGE ARRESTERS, CLASS I + II (B/C)

SURGE ARRESTERS, CLASS I (B)

SURGE ARRESTERS, CLASS II (C)

SURGE ARRESTERS, CLASS III (D)

SURGE ARRESTER

OVERVIEW OF CIRCUIT SYSTEMS AND USABLE LIGHTNING PROTECTION DEVICES

SCHRACK-INFO

The SCHRACK – SPD allows a easy connection for each system. It is not necessary to search and order different devices for system-protection.

TN-C SYSTEM

TN-S SYSTEM

TT SYSTEM

PROTEC T1 & T2
LPL I + II



IS211330



IS211340



IS211311

COMBTEC T1 & T2
LPL III + IV



IS211230



IS211240



IS211210

VARTEC T2 (II)
(OVERVOLTAGE
PROTECTION)



IS111130



IS111140



IS111110

VARTEC T3 (III)
(DEVICE
PROTECTION)



IS010002

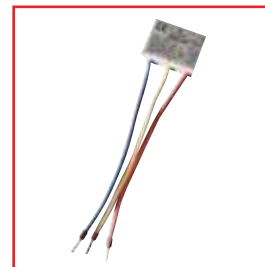

IS010003

SURGE ARRESTERS

WHEN CHOOSING A SURGE ARRESTER

Consider the detailed requirements in the following diagram and then select the appropriate switch type and surge arrester in the next section as appropriate to the mains system and protective action required.

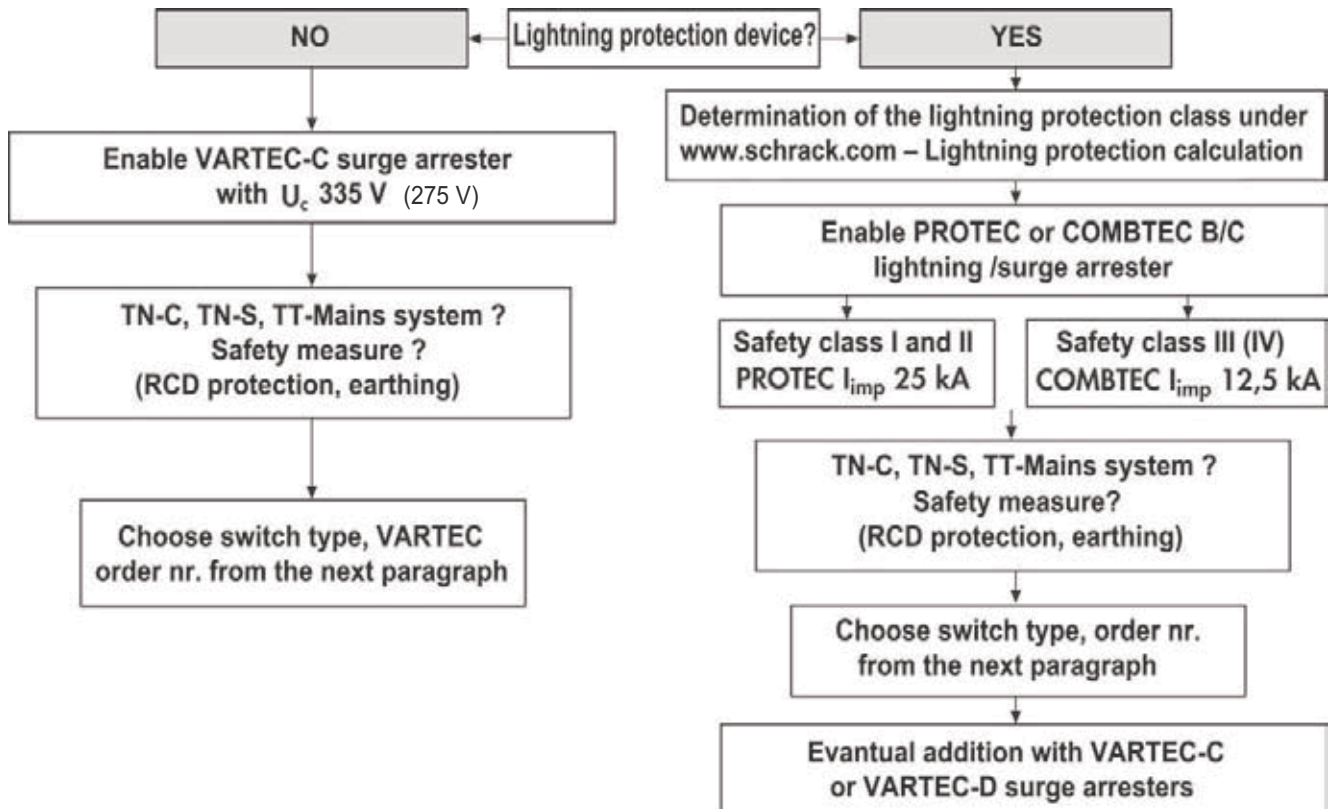

GENERAL INFORMATION – SPD TERMINOLOGY

- Surge Protection Device (SPD): device for limiting over-voltages.
- Maximum Continuous Operating Voltage (U_c): the maximum voltage which may be connected to the SPD (sometimes referred to as its “rated voltage”).
- Voltage Protective Level (U_p): the limiting voltage which appears across the terminals of an SPD under conduction of a surge of defined waveshape and amplitude. If no such waveshape or amplitude is defined, U_p is assumed to be stated when the SPD is subjected to the nominal discharge current I_n .
- Impulse Current (I_{imp}): peak value of current having a wave shape of 10/350 μ s. It is used in the classification of SPDs to test class I, for direct strike lightning discharges.
- Nominal Discharge Current (I_n): used in the classification of SPDs to test Class II. It shows the SPDs ability to withstand 15 impulses of peak magnitude I_n with an 8/20 μ s waveshape.
- Environmental Protective Rating (IP): the protective rating of the SPD enclosure against the environment e.g. water, dust etc.
- Disconnecter: a device, internal or external to the SPD, which is used to provide safe disconnection under fault conditions. Disconnecters may provide isolation by operating as thermal devices, or over current devices.
- Following Current (I_f): generally applies to voltage-switching type SPDs. This is the current delivered by the power distribution system which can be safely extinguished by the SPD during operation.

STANDARDS AND REFERENCES

- IEC 61643-1
- ÖVE NORM E 8001-1
- IEC 60364-4-443
- IEC 62305-1
- IEC 62305-2
- IEC 62305-3
- IEC 62305-4

SURGE ARRESTER

SURGE ARRESTERS FOR TNC-SYSTEM (PME / PEN CONDUCTOR)



IS211230

LIGHTNING ARRESTER (PROTEC, COMBTEC)

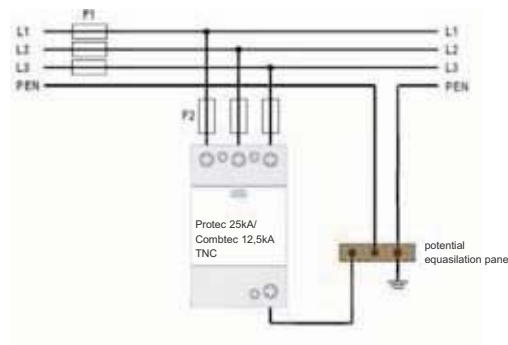

OVERVOLTAGE PROTECTION DEVICE (VARTEC)

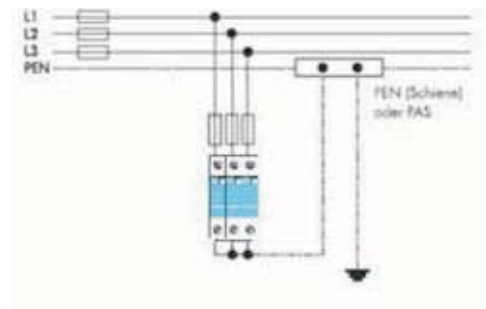

SCHRACK-INFO

Switches with relay contact usually have a "1" at the end of the article number, e.g. IS211331

DESCRIPTION	LIGHTING PROTECTION LEVEL	SPD-CLASS	ORDER NO.
Protec PTNC BC 275	LPL I + II	Testclass I + II	IS211330
Combtec CTNC BC 275	LPL III + IV	Testclass I + II	IS211230
Vartec TN-C Set 255	--	Testclass II	IS111130

SURGE ARRESTERS FOR TNS-SYSTEM (PEN CONDUCTOR SPLIT INTO PE & N)



IS211340

LIGHTNING ARRESTER (PROTEC, COMBTEC)

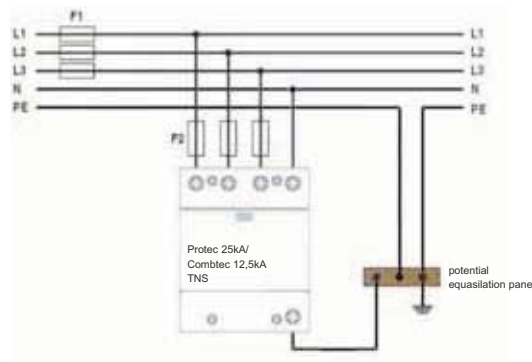

OVERVOLTAGE PROTECTION DEVICE (VARTEC)

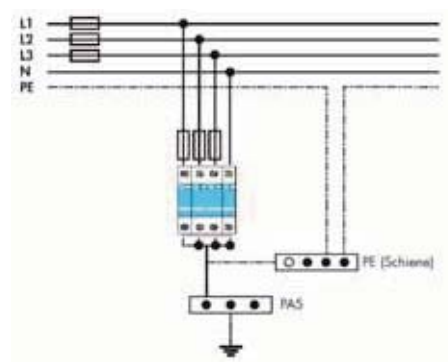

SCHRACK-INFO

No surge arrester is required for the Neutral conductor and the TN-C-SET can be used If the PEN conductor (protective multiple earthing connection) was separated in the immediate vicinity, e.g.in the upstream meter section.

Switches with relay contact usually have a "1" at the end of the article number, e.g. IS211341

DESCRIPTION	LIGHTING PROTECTION LEVEL	SPD-CLASS	ORDER NO.
Protec PTNS BC 275	LPL I + II	Testclass I + II	IS211340
Combtec CTNS BC 275	LPL III + IV	Testclass I + II	IS211240
Vartec TN-S Set 255	--	Testclass II	IS111140

SURGE ARRESTER

SURGE ARRESTERS FOR TT SYSTEM (PE CONDUCTOR)



IS211210

LIGHTNING ARRESTER (PROTEC, COMBTEC)

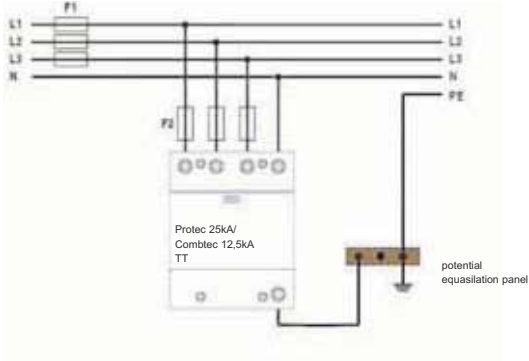

OVERVOLTAGE PROTECTION DEVICE (VARTEC)

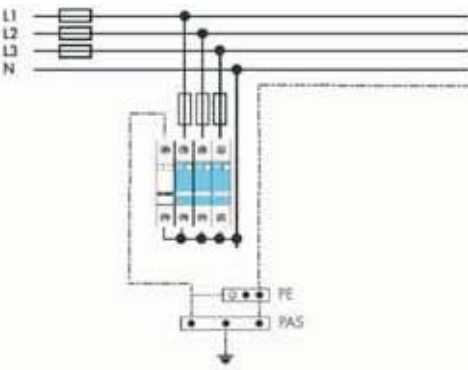

SCHRACK-INFO

Switches with relay contact usually have a "1" at the end of the article number, e.g. IS211211.

DESCRIPTION	LIGHTNING PROTECTION CLASS	SPD-CLASS	ORDER NO.
Protec PTT BC 275	LPL I + II	Testclass I + II	IS211311
Combtec CTT BC 275	LPL III + IV	Testclass I + II	IS211210
Vartec TT Set 255	--	Testclass II	IS111110

SURGE ARRESTERS, CLASS I + II (B/C) – 25 kA (10/350)

PROTEC 25 kA (10/350), CLASS I + II (LPL I + II)



IS211330

SCHRACK-INFO

The Schrack-Protec series has been developed to protect against partial direct and indirect discharges. It is intended to provide lightning protection level I and II (protection zone 0A to 1) according to IEC62305.

This series is tested for testclass I and testclass II according to IEC61643-1 with a maximum impulse current (Iimp) of 25kA (10/350) per pole and nominal discharge current (In) of 40kA (8/20) per pole. The devices are available for maximum continuous current operating voltage (Uc) of 275Vac.

Surge arrester class B/C, Class I/II, Type of design 1/2, meets EN/IEC-SN 60, part 4, and EN/IEC 61643.

INSTALLATION REQUIREMENTS

National regulations for installation must be followed!

In Austria: EN/IEC 8001-1, EN/IEC E 8049, EN/IEC 62305 or IEC 60364-5-53 A1.

RANGE OF APPLICATION

Varistor-lightning arresters/surge arresters designed for indoor mounting as a means of protecting consumer appliances against lightning and transient voltage surges. Can be used for construction systems with I and II classes of protection in accordance with EN/IEC E 8049 (EN/IEC 62305). The surge arrester operates in any position. The application of varistor technology extinguishes mains follow currents. It also ensures that connected devices are stress free and also offers a lower protection set off. No additional gas-filled blow-out spark gaps are required.

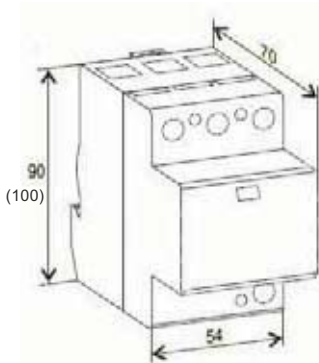

Protec PTNC 275/25

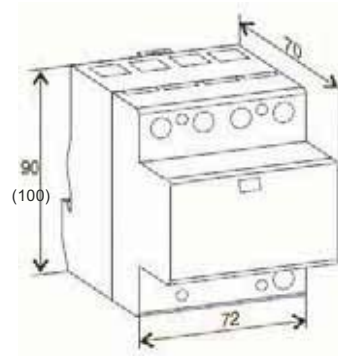

Protec PTNS 275/25

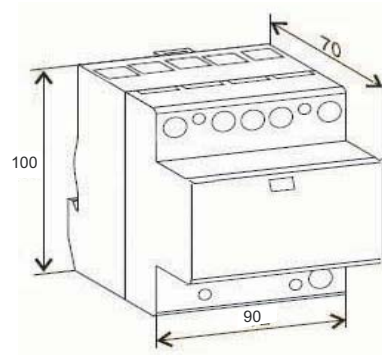

Protec PTT 275/25 + H

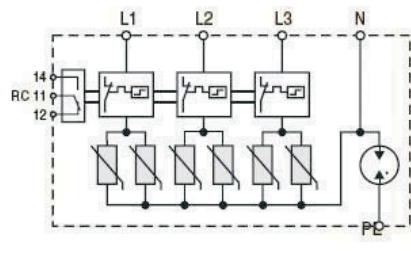
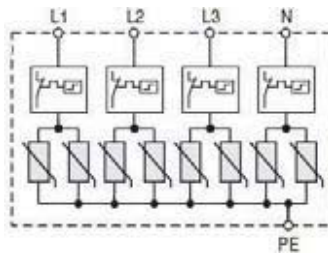
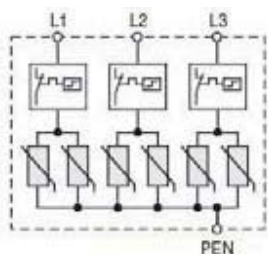

SURGE ARRESTERS, CLASS I + II (B/C) – 25 kA (10/350)

PROTEC 25 kA (10/350), CLASS I + II (LPL I + II) – continued

TECHNICAL DATA

	PTNC BC 275 (3+0)	PTNS BC 275 (4+0)	PTT BC 275 (3+1)
Standard	IEC61643-1		
Max. continuous voltage AC (DC)	275Vac (350Vdc)		
Nominal discharge current (I _{18/20}) per pole	40kA	40kA	40kA (MOV) 100kA (GDT)
Max. discharge current (I _{max 8/20}) per pole	100kA	100kA	100kA (MOV) 160kA (GDT)
Impulse current (I _{imp 10/350}) per pole	25kA	25kA	25kA (MOV) 100kA (GDT)
Specific energy per pole	156kJ/Ω	156kJ/Ω	156kJ/Ω(MOV) 2,5MJ/Ω(GDT)
Charge per pole	12,5As	12,5As	12,5As (MOV) 50As (GDT)
Protection level U _d	<1,4kV (at I ₁) <1,1kV (at I _{imp})	<1,4kV (at I ₁) <1,1kV (at I _{imp})	<1,4kV (at I ₁) (MOV) <1,1kV (at I _{imp}) (MOV)
Response time	<25ns	<25ns	<25ns (MOV) <100ns (GDT)
Follow current	-	-	>100A _{RMS}
Back-up fuse	max. 250A gL/gG	max. 250A gL/gG	max. 250A gL/gG
Short-circuit withstand current	25kA / 50Hz	25kA / 50Hz	25kA / 50Hz
Protection	Thermal protection	Thermal protection	Thermal protection
Terminal screw torque	max. 4,5Nm	max. 4,5Nm	max. 4,5Nm
Temperature range	-40°C - +80°C	-40°C - +80°C	-40°C - +80°C
Terminal cross section	35mm ² (solid) / 25mm ² (stranded)	35mm ² (solid) / 25mm ² (stranded)	35mm ² (solid) / 25mm ² (stranded)
Degree of protection	IP20	IP20	IP20
Housing material	Thermoplastic; ext. degree UL94 V-0	Thermoplastic; ext. degree UL94 V-0	Thermoplastic; ext. degree UL94 V-0
Dimensions DIN43880	3TE	4TE	5TE
Art.No. (without remote contact)	IS211330	IS211340	IS211311

DESCRIPTION	LIGHTING PROTECTION LEVEL	SPD-CLASS	ORDER NO.
Protec PTNC BC 275	LPL I + II	Testclass I + II	IS211330
Protec PTNC BC 275 + H	LPL I + II	Testclass I + II	IS211331
Protec PTNS BC 275	LPL I + II	Testclass I + II	IS211340
Protec PTNS BC 275 + H	LPL I + II	Testclass I + II	IS211341
Protec PTT BC 275	LPL I + II	Testclass I + II	IS211311
CU-Busbar (SPD-FI) TNS (not useable for Protec TT system)			IS050019
CU-Busbar (SPD-FI) TNC			IS050020

SURGE ARRESTERS, CLASS I + II (B/C) – 12,5 kA (10/350)

COMBTEC 12,5 kA (10/350), CLASS I + II (LPL III + IV)



IS211230

SCHRACK-INFO

The Schrack-Combtec series has been developed to protect against partial direct and indirect discharges. It is intended to provide lightning protection level III and IV (protection zone 0A to 1) according to IEC62305.

This series is tested for testclass I and testclass II according to IEC61643-1 with a maximum impulse current (I_{imp}) of 12,5kA (10/350) per pole and nominal discharge current (I_n) of 20kA (8/20) per pole. The devices are available for maximum continuous current operating voltage (U_c) of 275Vac and 335Vac.

For each path: Class B/C, type of design I/II, type 1/2, EN/IEC-SN 60, part 4, / EN/IEC 61643 approved.

INSTALLATION REQUIREMENTS

National regulations for installation must be followed!

In Austria: EN/IEC 8001-1, EN/IEC E 8049, EN/IEC 62305 or IEC 60364-5-53 A1.

RANGE OF APPLICATION

Combined lightning arresters/surge arresters designed for indoor mounting as a means of protecting consumer appliances against lightning and transient surge voltages. Are ideally used for construction systems having protection class III and (IV) according to ÖVE/ÖNORM E 8049. Surge arrester operates in all locations. Coupling VV-SG50-VS surge arresters provide a low protection level in a variety of network systems (TT/IT/TN-C/TN-C-S) with the width of an RCCB of only 4 MW (3+1 switching operation 6 MW) without any mains follow currents.

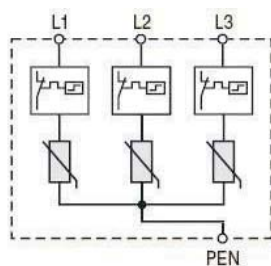
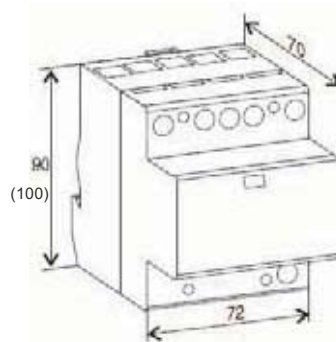
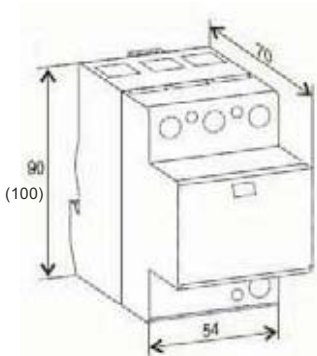

Combtec CTNC 275/12,5

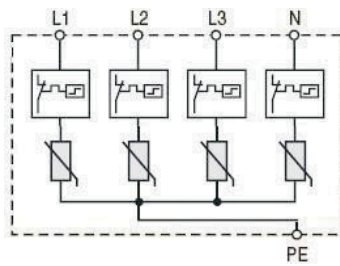

Combtec CTNS 275/12,5

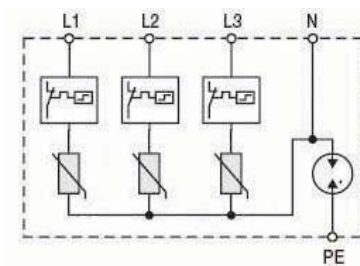

Combtec CTT 275/12,5

SURGE ARRESTERS, CLASS I + II (B/C) – 12,5 kA (10/350)

COMBTEC 12,5 kA (10/350), CLASS I + II (LPL III + IV) – continued

TECHNICAL DATA

	CTNC BC 275 (3+0)	CTNS BC 275 (4+0)	CTT BC 275 (3+1)
Standard	IEC61643-1		
Max. continuous voltage AC (DC)	275Vac (350Vdc)		
Nominal discharge current (I _{18/20}) per pole	20kA	20kA	20kA (MOV) 50kA (GDT)
Max. discharge current (I _{max 8/20}) per pole	50kA	50kA	50kA (MOV) 100kA (GDT)
Impulse current (I _{imp 10/350}) per pole	12,5kA	12,5kA	12,5kA (MOV) 50kA (GDT)
Specific energy per pole	39kJ/Ω	39kJ/Ω	39kJ/Ω(MOV) 625kJ/Ω(GDT)
Charge per pole	6,25As	6,25As	6,25As (MOV) 25As (GDT)
Protection level U	<1,4kV (at I ₁) <1,0kV (at I _{imp})	<1,4kV (at I ₁) <1,0kV (at I _{imp})	<1,4kV (at I ₁) (MOV) <1,0kV (at I _{imp}) (MOV)
Response time	<25ns	<25ns	<25ns (MOV) <100ns (GDT)
Follow current	-	-	>100A _{RMS}
Back-up fuse	max. 250A gL/gG	max. 250A gL/gG	max. 250A gL/gG
Short-circuit withstand current	25kA / 50Hz	25kA / 50Hz	25kA / 50Hz
Protection	Thermal protection	Thermal protection	Thermal protection
Terminal screw torque	max. 4,5Nm	max. 4,5Nm	max. 4,5Nm
Temperature range	-40°C - +80°C	-40°C - +80°C	-40°C - +80°C
Terminal cross section	35mm ² (solid) / 25mm ² (stranded)	35mm ² (solid) / 25mm ² (stranded)	35mm ² (solid) / 25mm ² (stranded)
Degree of protection	IP20	IP20	IP20
Housing material	Thermoplastic; ext. degree UL94 V-0	Thermoplastic; ext. degree UL94 V-0	Thermoplastic; ext. degree UL94 V-0
Dimensions DIN43880	3TE	4TE	5TE
Art.No. (without remote contact)	IS211230	IS211240	IS211210

DESCRIPTION	LIGHTING PROTECTION LEVEL	SPD-CLASS	ORDER NO.
Combtec CTNC BC 275	LPL III + IV	Testclass I + II	IS211230
Combtec CTNC BC 275 + H	LPL III + IV	Testclass I + II	IS211231
Combtec CTNS BC 275	LPL III + IV	Testclass I + II	IS211240
Combtec CTNS BC 275 + H	LPL III + IV	Testclass I + II	IS211241
Combtec CTT BC 275	LPL III + IV	Testclass I + II	IS211210
Combtec CTT BC 275 + H	LPL III + IV	Testclass I + II	IS211211
Combtec CTNC BCD 275 + H	LPL III + IV	Testclass I + II + III	IS211431
Combtec CTNS BCD 275 + H	LPL III + IV	Testclass I + II + III	IS211441
Combtec CTT BCD 275 + H	LPL III + IV	Testclass I + II + III	IS211411
CU-Busbar (SPD-FI) TT, TNS			IS050019
CU-Busbar (SPD-FI) TNC			IS050020

SURGE ARRESTERS, CLASS I + II (B/C)

SURGE ARRESTER B/C, PROTEC 25 kA SERIES



ISO10091



ISO10092

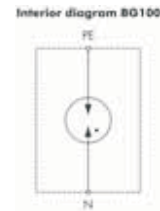
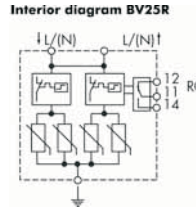
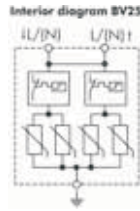
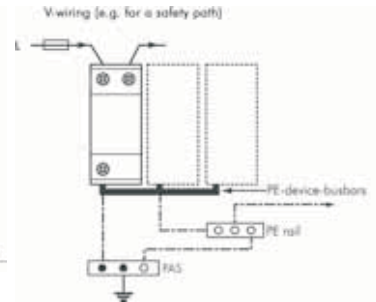
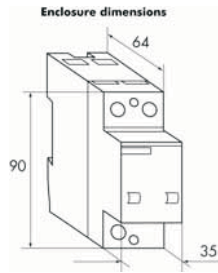

BV 25-275* BVR 25-275*

BG100

Varistor

N/PE Gas surge arrester

Continuous voltage U_c	275 VAC
Nominal discharge current I_n (8/20 μ s)	40 kA
Max. discharge current I_{max} (8/20 μ s)	100 kA
Lightning impulse current I_{imp} (10/350 μ s)	25 kA
Protection level U_p at I_n) 1600 V
Protection level U_p of I_{imp}) 1250 V
Protection level U_p (gas surge arrester)-(1,2/50 μ s)	—
Response time t_d	< 25 ns

255 VAC

100 kA

150 kA

100 kA

—

—

) 1200 kV

< 100 ns

Max. permissible ambient temperature	-40° C up to +80° C
Degree of protection open/installed	IP 20/40
Max. permissible fuse:	250 AgL
Short-circuit protection with max. fuse	25 kA / 50 Hz
Enclosure material	Thermoplastic, self-extinguishing
Max. terminal cross section	25/35 mm ²
DIN-rail mountable	both sides, top terminals for V wiring
Model with auxiliary contact	BVR 25-275/335
Auxillary contacts	250 V AC/0,5 A, max. 1,5 mm ²

*) Us N-/PE surge arrester ISO 10094 when using the 3+1 switching operation.

DESCRIPTION	DIM. (WxHxD) mm	ORDER NO.
Protec BV 25 kA EN/IEC'	35x90x64	ISO10091
Protec BVR 25 kA +H IEC'	35x90x64	ISO10195
Lightning arrester 100 kA	-	ISO10094
CU-Busbar, 3x f. TN-C network	-	ISO10173
CU-Busbar, 4x f. TN-S TT network	-	ISO10174

SURGE ARRESTERS, CLASS I + II (B/C)

SURGE ARRESTER CLASS B/C, COMBTEC SERIES, 12,5 kA



IS010081



IS010083

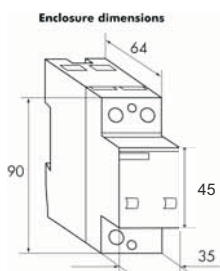

Interior diagram VV

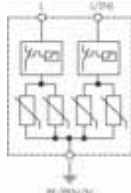

Interior diagram VVR

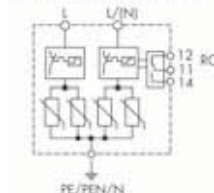

Interior diagram VS

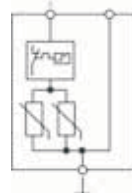

Interior diagram VSR

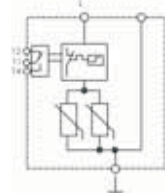

	VV 275*	VS275*
	Varistor	Varistor
Continuous voltage U_c	275 VAC	275 V AC
Nominal discharge current I_n (8/20 μ s)	40 kA	40 kA
Max. discharge current I_{max} (8/20 μ s)	80 kA	80 kA
Lightning impulse current I_{imp} (10/350 μ s)	12.5 kA	12.5 kA
Protection level U_d at I_n) 1,8 kV	* 1,8 kV
Protection level U_d at I_{imp}) 1,2 kV) 1,2 kV
Response time t_d	< 25 ns	< 25 ns
Max. permissible ambient temperature	-40° C up to +80° C	
Degree of protection open/installed	IP 20/40	
Max. permissible fuse:	250 AgL	
Short-circuit protection with max. fuse	25 kA/50Hz	
Enclosure material	Thermoplastic, self-extinguishing V0	
Max. terminal cross section	25/35 mm ²	
DIN-rail mountable	on both sides	
Model with auxiliary contact	VVR 335	VSR 335
Auxillary contacts	250 V AC/0,5 A, max. 1,5 mm ²	

*) Use N/PE surge arrester IS010084 when using the 3+1 switching operation.

DESCRIPTION	DIM. (WxHxD) mm	ORDER NO.
Combtec VS 12,5 kA IEC ¹⁾	35x90x64	IS010183
Combtec VV 12,5 kA IEC ¹⁾	35x90x64	IS010181
Combtec VSR 12,5 kA+H IEC ¹⁾	35x90x64	IS010187
CU-Busbar, 2x f. TN-C network	35x90x64	IS010172
Lighting arrester N/PE-50 kA, SG50	35x90x64	IS010084
CU-Busbar, 3x f. TN-C network	-	IS010173
CU-Busbar, 4x f. TN-S TT network	-	IS010174

1) ÖVE/ÖNORM design according to ÖVE/ÖNORM 8001-1, section 18. Must be implemented by law in Austria.

SURGE ARRESTERS, CLASS I (B)

LIGHTNING ARRESTER 25 / 60 kA WITH SPARK GAP, POWERTEC SERIES



IS010111/IS010112/IS010113/IS010114

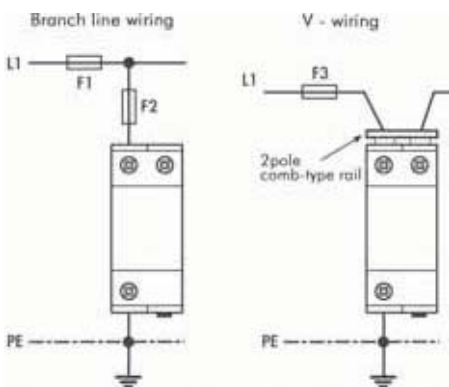
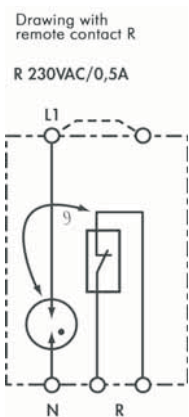
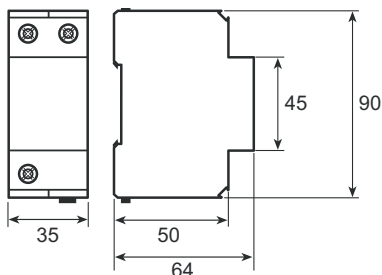

If conductor safety fuse (F1) ≤ 160 A is used, there is no need for the back-up fuse (F2).

SCHRACK-INFO

- Level of protection) 2,5 kV
- No blow-out opening, hence no need for spark gaps
- Optional relay contact
- Test current 25 kA, 60 kA (10/350µs)
- High Insulation resistance $R_{isol} > 10^{10} \Omega$
- Rated voltage U_c : 335 V~
- Nominal operating voltage U_n : 230 / 400 V AC 50/60 Hz
- Response time < 50 ns
- Max. permissible conductor/back-up fuse F2 with single drop 160 A gL
- Max. permissible conductor/back-up fuse F3 with V-wiring: 100 A gL
- Operating temperature range: -40° C up to +85° C
- Max. cable cross-section: multi-wired 50 mm² / fine-wired 35 mm²
- Enclosure material / colour: Polycarbonate (halogen-free)/ grey RAL 7035
- Degree of protection: IP 20
- Mounted on DIN-rail 35 mm accord. to EN 50 022

CERTIFICATIONS

tested in accordance with E DIN VDE 0675-6-11/98-A1 and EN 61643-11 /IEC 61643-1 and ÖVE 8001-1.
Classification accord. to class B/C, I + II, T1/T2

PRODUCT DESCRIPTION:

POWERTEC 25, 60 (R) with a low protection level is a selective, two-level T1 + T2 (B+C) surge arrester, which combines protection classes I+II in a single device. This means no decoupling elements are required for cable lengths under 10 m. Using hermetically sealed spark gaps filled with inert gas means that the requirement of a high discharge capacity is fulfilled while maintaining functional stability. The first level (non-linear resistor type arrester) discharges impact currents (up to 4kA) without causing any mains follow-currents. When a pre-defined impact current (up to 4 kA) has been exceeded, the second level (the hermetically sealed spark gap filled with inert gas) engages for the less common discharge of high-energy transients up to 25 kA / 60 kA (10/350 µs) which may arise during close-up or direct lightning strikes. As an option, a potential-free relay contact (R) with terminal is included in the enclosure- to aid signalling.

V-wiring can be easily installed using the unlabelled terminal (the one not connected with the L/N terminal in the device) using the optional 2-pole comb-type rail.

DESCRIPTION	DIM. (WxHxD) mm	ORDER NO.
Lightning arrester, 25 kA, Class I/II, B/C	35x90x64	IS010111
Lightning arrester, 25 kA+H, Class I/II, B/C	35x90x64	IS010112
Lightning arr. 60 kA, Class I/II, B/C	35x90x64	IS010113
Lightning arr. 60 kA+H, Class I/II, B/C	35x90x64	IS010114
CU-Busbar, 3x f. TN-C network	-	IS010173
CU-Busbar, 4x f. TN-S, TT network	-	IS010174

SURGE ARRESTERS, CLASS I (B)

N/PE LIGHTNING ARRESTER, 50 kA / 100 kA (10/350) μ S, SG50, G100



IS010084/IS010094

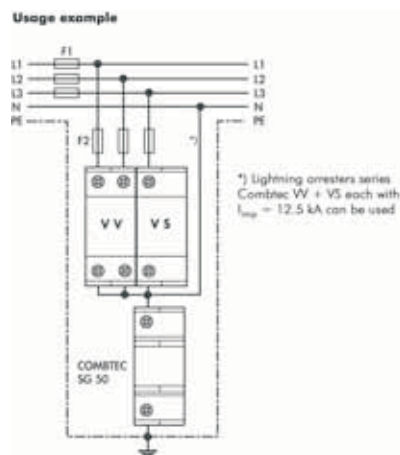
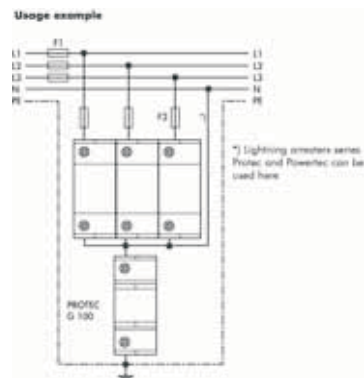
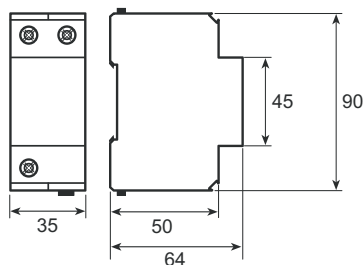

Surge protector



SCHRACK-INFO

- N/PE Spark-gap based lightning arrester, for use in 3+1 switching operation
- No leakage current
- No blow-out opening, hence no need for spark gaps
- Test current 50 kA / 100 kA (10/350 μ s) meeting lightning protection class III, (IV)
- High Insulation resistance $R_{501} > 10^{10} \Omega$
- Level of protection < 1.5 kV
- High follow-current reset capability
- Multi-functional lift terminal for conductor and comb-type rail
- Nominal mains and operating voltage U_n : 230 / 400 V AC 50/60 Hz
- Rated voltage U_r : 225 V AC 50/60 Hz
- Response time < 50 ns
- Follow-current reset capability at U_n (50/60Hz) up to 100 Aeff / 200 Aeff
- Short-circuit protection with max. back up fuse 160A gL: 25 kAeff
- Operating temperature range: -40° C up to $+85^\circ$ C
- Max. cable cross-section: multi-wired 50 mm² / fine-wired 35 mm²
- Enclosure material / colour: Polycarbonate (halogen-free)/ grey RAL 7035
- Degree of protection: IP 20
- Mounted on top-hat rail 35mm accord. to EN 50022

CERTIFICATIONS

Test in accordance with EN 61643-11 & IEC 61643-1, ÖVE 8001-1

RANGE OF APPLICATION

SG50 used in combination with COMBTEC VV, VS, G100 in combination with PROTEC, POWERTEC in 3 + 1 switching operation is used to protect against direct lightning strikes in external overhead lines or external lightning arrester in the TT system. See graphic for application.

PRODUCT DESCRIPTION:

SG 50, G 100 are 1-pole N/PE lightning arresters with protection class I+II+III (B+C+D) for protection against partial lightning currents from entering electrical installations. The device is used for equipotential bonding of lightning protection in the 400/230 VAC TT system, as a N/PE conductor with 3 + 1 switching operation.

It is able to deflect lightning currents up to 50 kA / 100 kA (10/350 μ s) with a charge of 50 As, and has a low protection level, $U_p < 1.5$ kV.

The use of a hermetically-sealed high-performance spark-gap filled with inert gas makes use of a dangerous blow-out opening superfluous.

INSTALLATION- AND OPERATING NOTES:

A gap need no longer be enforced between neighbouring cables and components to prevent arcing faults. Given that this arrester is required to deflect high lightning currents, we recommend the use of single-wire Cu conductors upwards of 16 mm². The entire length of the connection must not exceed 0.5 m. If this cannot be ensured, install the PE conductor with an extra terminal V-formed where possible.

SURGE ARRESTERS, CLASS I (B)

N/PE LIGHTNING ARRESTER, 50 kA / 100 kA (10/350) μ S, SG50, G100 – continued

CAUTION:

The SG 50, G 100 must only be installed by specialist electricians. All valid norms must be observed during mounting and installation. This device must only be used as a N/PE aggregate-lightning arrester in the 3+1 switching operation, appropriate to the lightning protection class.

FAULT DETECTION

When required, this arrester can also be tested using an insulation meter. When Risol 0.5 to 1 M Ω the arrester must be replaced at the next opportunity, when Risol < 0.5 M Ω it must be replaced immediately.

DESCRIPTION	DIM. (WxHxD) mm	ORDER NO.
N/PE lightning arrester, 50 kA, SG50,	35x90x64	IS010084
N/PE lightning arrester, 100kA G100	35x90x64	IS010094
CU-Busbar, 4x f. TN-S TT network	-	IS010174

SURGE ARRESTERS, CLASS II (C)

PLUG-IN SURGE ARRESTER, VARTEC VVP, DVP SERIES



7N5B4976



7N5B4990



7N5B4992



7N5B4994

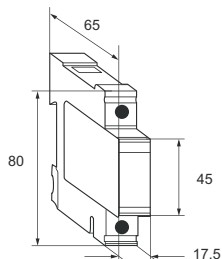

SCHRACK-INFO

Class C, design type II, type 2, meets ÖVE-SN 60, part 4 & EN/IEC 61643

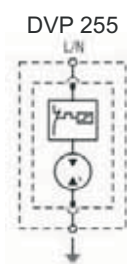
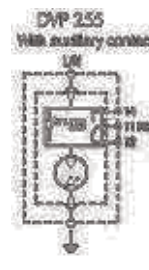
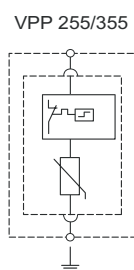
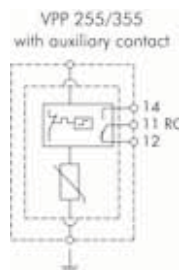

	VVP 255 Varistor	VVP 335 Varistor	DVP 255 ²⁾ Gas-filled surge arrester
Continuous voltage U_c	255 VAC	335 VAC	255 VAC
Nominal discharge current I_n (8/20 μ s)	15 kA/20 kA	15 kA/20 kA	20 kA
Max. discharge current I_{max} (8/20 μ s)	30 kA/40 (30) kA	30 kA/40 (30) kA	40 kA
Protection level U_p at I_n) 1,3/1.4 kV) 1,4 kV/1,65 kV) 1,2 kV
Response time t_d	< 25 ns	< 25 ns	< 100 ns
Max. permissible ambient temperature		-40° C up to +80° C	
Degree of protection open/installed		IP 20/40	
Max. permissible fuse:	100 A	100 A	
Max. terminal cross section		16/25 mm ²	
Auxiliary contact (optional)		250 V AC/0,5 A, max. 1,5 mm ² on both sides	
DIN-rail mountable			
Max. terminal torque		2,5 - 3,0 Nm (main terminal)	

SURGE ARRESTERS, CLASS II (C)

PLUG-IN SURGE ARRESTER, VARTEC VVP, DVP SERIES – continued

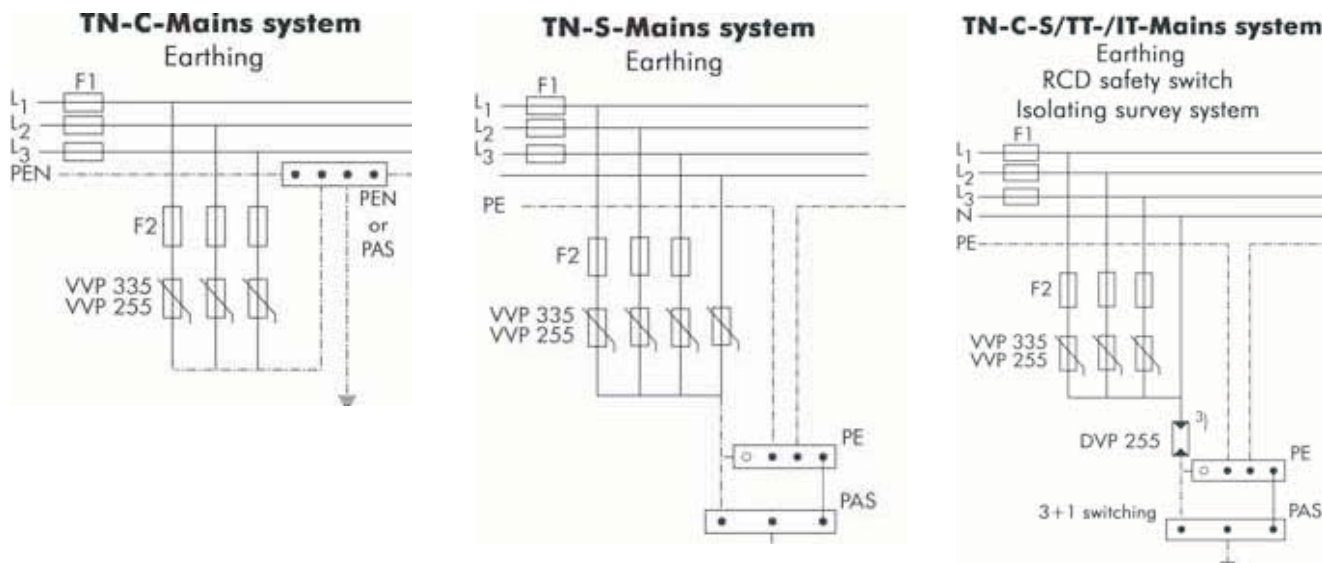

TIPS & TRICKS

Observe the respective national regulation for installation! E.g. ÖVE 8001-1 or IEC 60361-5-53 A1. The neutral contactor does not require a surge protection device (in accordance with the TN-C switching arrangement) if the protective multiple earthing connection is set up where the surge protection device is integrated.

The connection line to the equipotential bonding rail or PE rail should be as short as possible and without looping. All surge devices must be unplugged during insulation measurement.

The VVP335 surge arrester has been designed for mains voltages of 3~400/230 V in accordance with ÖVE 8001-1. According to IEC 603645-5-53 A1, the VVP255 surge arrester is for export only.

RANGE OF APPLICATION

Plug-in surge arresters designed for indoor mounting as a means of protecting consumer appliances against lightning and transient voltage surges. The surge arrester operates in any position. Terminal assignment for the mains and PE/PEN-conductor is freely definable.

DESCRIPTION	ORDER NO.
C-arrester module 15 kA ÖVE VVP335	IS010078
C-arrester module 20 kA ÖVE VVP335	IS010079
C-arrester module 15 kA IEC VVP255	IS010076
C-arrester module 20 kA IEC VVP255	IS010077
N-PE surge arrester Module 20kA DVP255	IS010075
Base,1-pol. for VVP	IS010071-A
Base,1-pol. for VVP +H	IS010069-A
Base,1-pol. for DVP	IS010070-A
Base,1-pol. for DVP +H	IS010068-A
Base 3+1 operation	IS010064-A
Base 3+1 operation +H	IS010065-A
Busbar, 3x, insulated, for TN-C system	IS050103
Busbar, 4x, insulated, for TN-S, TT system	IS050104
Busbar, 5x, insulated, for N arrangement	IS050105

¹⁾ ÖVE design according to ÖVE 8001-1, section 18. Must be implemented by law in Austria.

²⁾ As specified in ÖNORM/ÖVE E8001-1, the 20kA requirement still applies to the surge arrester between Neutral and the main earthing rail (N/PE conductor). (PAS) or PE-rail, even in cases where surge protection devices were installed with greater nominal discharge currents, e.g. 15 kA or 20 kA between the external conductors and the Neutral conductor.

SURGE ARRESTERS, CLASS II (C)

VARTEC SURGE ARRESTER CLASS C, VEPG SERIES FOR SINGLE-PHASE OPERATION, 230 VAC, 1 MODUL WIDE



IS010073

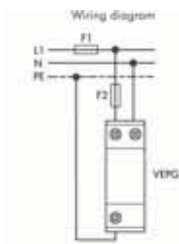
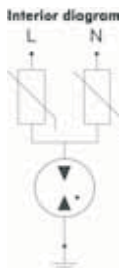

F2 only necessary when F2 > 35 A/g.

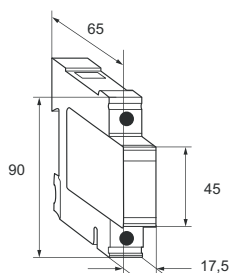

SCHRACK-INFO

Class C, design type II, type 2,
meets ÖVE 60, part 4 & EN/IEC 61643

TECHNICAL DATA

- Space saving - only 1 module wide
- Ideal for retrofits (renovating old buildings)
- D surge arrester, protection level
(U_p 950 V at 5 kA I_n (8/20))
- High back-up fuse possible
- National regulations for installation must be followed!

RANGE OF APPLICATION

Surge arresters designed for indoor mounting as a means of protecting consumer appliances against lightning and transient voltage surges. The surge arrester operates in any position. The connection line to the equipotential bonding rail or PE rail should be as short as possible and without looping. When measuring insulation, the surge arrester is disconnected from PE by the gas-filled spark gap.

- Continuous voltage U_c
- Nominal discharge current I_n (8/20 μ s)
 I_{max} (8/20 μ s)
- Level of protection U_p at I_n
- Response time t_d
- Max. permissible ambient temperature
- Degree of protection open/installed
- Max. permissible fuse:
- Max. terminal cross section
- Auxiliary contact (optional)

VEPG

Varistor + gas surge arrester

335 VAC

10 kA / PoI

20 kA / PoI

) 1,6 kV at 5 kA 950 V

< 100 ns

-40° C up to +80° C

IP 20/40

100 A

L, N = 6 mm²; PE = 25/35 mm²

250 VAC / 0,5 A; max. 1,5 mm²

DESCRIPTION	DIM. (WxHxD) mm	ORDER NO.
C surge arrester, 10 kA, 335 V, 1-phase, 1 modul wide	17,5x90x65	IS010073
Base for VMG / VEPG	-	IS010201
Base + H for VMG / VEPG	-	IS010202

SURGE ARRESTERS, CLASS III (D)

PLUG-IN SURGE ARRESTER, D CLASS, VMG SERIES FOR SINGLE PHASE OPERATION, 230 V, 1 MODUL WIDE, DIN-RAIL



IS010200



IS010201



IS010200

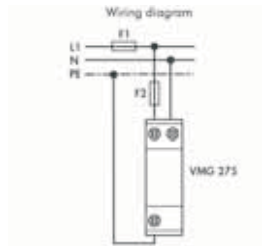

F2 only necessary when F2 > 63 A

SCHRACK-INFO

Class D, design type II, type 2,
meets ÖVE-SN 60, part 4 & EN/IEC 61643

TECHNICAL DATA

- National regulations for installation must be followed!
- Space saving - only 1 module wide
- Plug-in module
- N/PE - spark gap already fitted
- Low level of protection
- High back-up fuse possible

RANGE OF APPLICATION

D class surge arresters designed for indoor mounting as a means of protecting consumer appliances against lightning and transient voltage surges. The surge arrester operates in any position. The connection line to the equipotential bonding rail or PE rail should be as short and possible and without looping. When measuring insulation, the surge arrester is disconnected from PE by the gas-filled spark gap. Only for use in TN systems.

- Continuous voltage U_c
- Nominal discharge current I_n (8/20 μ s)
 U_{oc} (1,2/50)
- Protection level U_p at I_n
- Response time t_d
- Max. permissible ambient temperature
- Degree of protection open/installed
- Max. permissible fuse:
- Max. terminal cross section
- Auxiliary contact (optional)
- DIN-rail mountable

VMG 275

Varistor + gas surge arrester

275 VAC

3 kA / Pol

6 kV / Pol

) 0.9 V

< 100ns

-40° C up to +80° C

IP 20/40

63 A

L, N = 6 mm²; PE = 25/35 mm²

250 VAC / 0,5 A; max. 1,5 mm²

on both sides

DESCRIPTION	ORDER NO.
D surge arrester Module 3kA, 1 MW	IS010200
Base for VMG / VEPG	IS010201
Base + H for VMG / VEPG	IS010202

SURGE ARRESTERS, CLASS III (D)

PLUG SOCKETS – INSERTABLE PROTECTION MODULE



IS010002

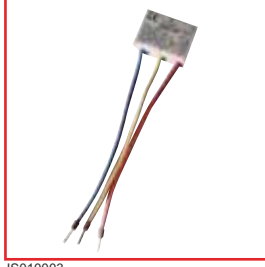

IS010003

Mounting indicators

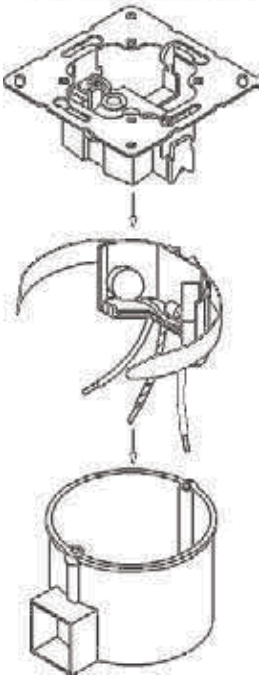

SCHRACK-INFO

- Requirement class D
- Rated discharge current $(8/20 \mu s)_{sh}$: 2.5 kA
- Rated voltage U_c : 250 V~ (50Hz)
- Max. load circuit current I_{max} : 16 A
- Connection type: 3 wire
- Response time: L - N < 25 ns
- Short-circuit protection: 6 kA (back-up fuse 16 AgL)
- Temperature range: -20° C to 60° C

TECHNICAL DATA

For the equipping of new and retrofitting of existing earthed sockets. Can be integrated in flush-mounted enclosure boxes. Through-wiring model enables other plug sockets to be connected.

RANGE OF APPLICATION

The protective device is primarily designed for fusing sensitive electronic devices mains-side, and is suitable for universal application in flush-mounted modular device- and enclosure sockets. This device allows you to equip already existing flush-mounted plug sockets with surge protection. The protective device is clamped into a FM- device insert using a spring clip after the L, N and PE conductors are connected to the plug socket- on the device side. Afterwards, the plug socket is mounted as usual.

This enables the user not only to equip plug sockets to be installed for the first time but also to retrofit existing plug sockets, regardless of individual models of different manufacturers. The switching operation of the device provides parallel protection. This ensures that supply to the protected device- mains-side is maintained even if the protective device is damaged. Fault indication is provided by a sensor integrated in the device. This indicates when protection is no longer provided, in which case the protective device should be replaced by an electrician as soon as possible.

DESCRIPTION	ORDER NO.
D Surge arrester for plug socket, 2,5 kA, through-wiring	IS010002
D Surge arrester for plug socket, 3 kA, 16 A	IS010003